

Installation instructions for rubber actuator (without accessories)



Type Valve: 01353 (Globe), 09343 (Gate)

Type actuator: rubber



Attention:

The included operating and installation instructions for the Valve, must be read before starting the installation and/or operation.
Air connection actuator: Push-In connection for air tube outside diameter 8,0mm. Operating air pressure: 6,0 bar (maximum 10,0 bar)

A safe operation of the complete valve is only be guaranteed, if the installation, first operation and maintenance will be carried out by qualified persons who are familiar with the installation, assembly, start up and operation of the product.

Furthermore pay attention to the general installation and safety rules and standards for piping resp. facility construction.

For replacement of the actuator the following points/steps must be observed:



Dismantling of the rubber actuator:

1. The actuator must be controlled pressurised with maximum 2,0 bar operating pressure for positioning the actuator stem „Valve open“
2. Dismantle the bolts (Item 10 of drawing2)
3. Take of the pressurised complete topwork with actuator from the Globe Valve, than controlled depressurise of the actuator to zero pressure
4. Dismantle the hexagon nut M12 (Item 6 of drawing1) by holding the stem at point SW22 (see drawing2) with a wrench A/F 22 avoiding a turning of the stem.
5. Dismantle the top plate (Item 3 of drawing1) by screwing out the bolts M10x20 (Item 4 of drawing1) using the included “Inbus wrench”
6. Dismantle the rubber actuator (Item 2 of drawing1) by screwing out the bolts M10x20 (Item 4 of drawing1) using the included “Inbus wrench”
7. Replace the old O-rings by the included new O-rings, if necessary

Assembling:

1. Assemble the rubber actuator (Item 2 of drawing1) onto the bottom plate (Item 1 of drawing1) **ATTENTION:** the holes of the rubber actuator and bottom plate must be in line for later pressurising
2. Assemble the bolts M10x20 (Item 4 of drawing1) using the included “Inbus wrench”
3. Assemble the top plate (Item 3 of drawing1) onto the rubber actuator (Item 2 of drawing1) by screwing in the bolts M10x20 (Item 4 of drawing1) using the included “Inbus wrench”
4. Assemble the distance bush (Item 5 of drawing1) and the hexagon nut M12 (Item 6 of drawing1) by holding the stem at point SW22 (see drawing2) with a wrench A/F 22 avoiding a turning of the stem.
5. Place the bonnet gasket (Item 20 of drawing2) into the top flange of the valve body.
6. The actuator must be controlled pressurised with maximum 2,0 bar operating pressure for positioning the actuator stem „Valve open“
7. Assemble the pressurised complete topwork onto the valve body by using the bolts (Item 10 of drawing2) Torque: DN40=70Nm / DN50=50Nm / DN65=90Nm, than controlled depressurise of the actuator to zero pressure
8. Tighten and control all screwed parts (nuts)

Drawing1

Kopie nicht maßstäblich!

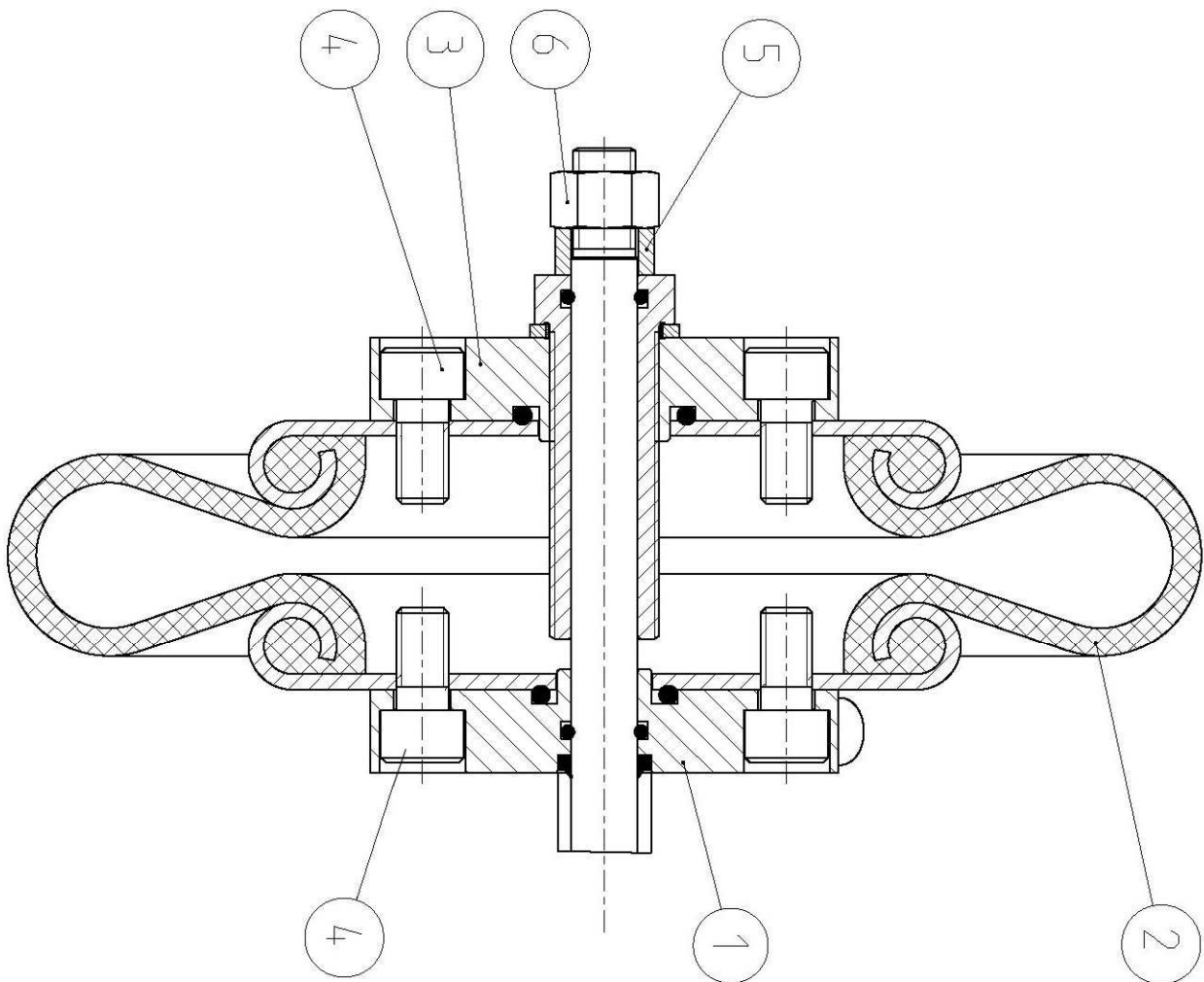

Drawing2

